



The Mini Air Screen

Modular Design Advantages

- Low cost initial investment
- Basic units have the same heavy duty construction as the larger units
- Very low maintenance
- Screens can be replaced easily for different types of cleaning
- Modules for air separation, metering feed, and additional screen area available



Other Features

Gentle vibratory feeder for 0% damage to crops

Aggressive design enables handling of rough materials

All standard bearings and replacement parts

Designed and built by seeds men

Manufactured in the U.S.A.

Large air settling chambers for even & accurate air separation

Low HP requirements, 1/2 HP on machine and 2 HP on fan

Large selection of screens available; from 13.5 square feet to 240 square feet

Screens available in all steel construction

P.O. Box 3167, Great Falls, MT 59403 Ph. 406-727-6514 or 1-800-977-6514

www.benchindustries.com

Flow Diagram

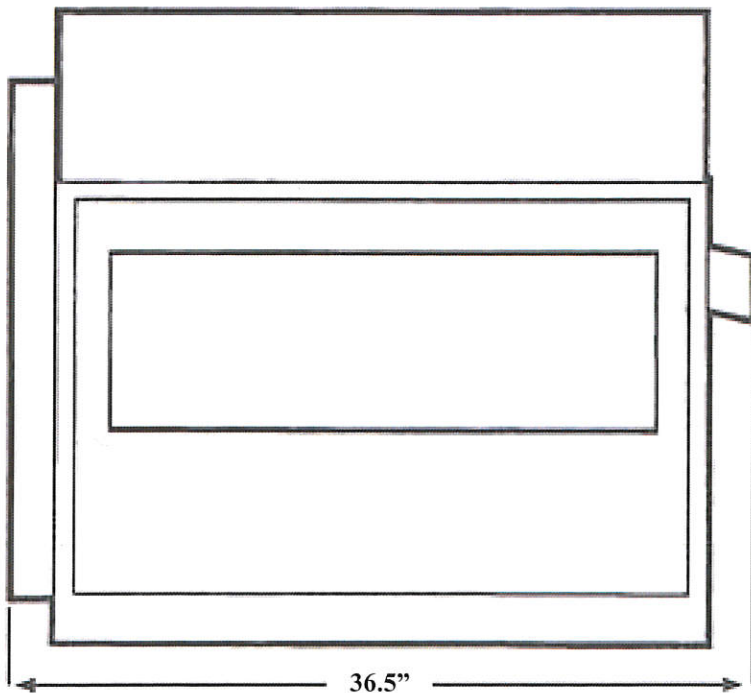
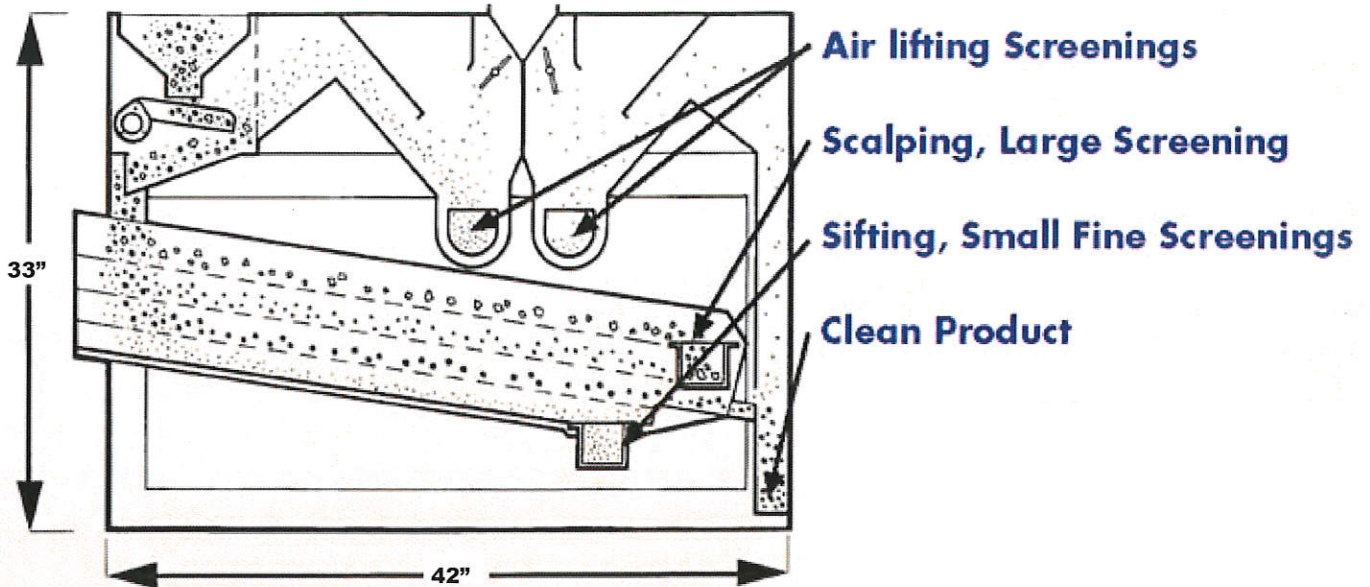

Specifications

	Precleaning	Seed Cleaning
Capacity	125 b.u.	30-70 b.u.
Screen Area	13.5 sq. feet	

Power Requirements

Fan	2 hp.
Shoe	1/2 hp.
Air Volume	up to 2300 cfm
Shipping Weight	580 lbs.

Capacities will vary on type of product and foreign material to be removed