

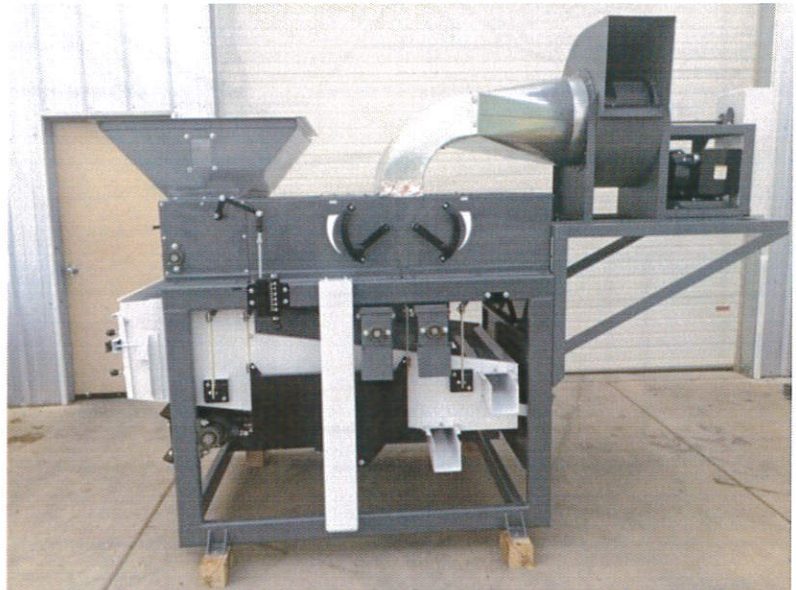

Mid-Range Air Screen

Modular Design Advantages

- Low cost initial investment
- Basic units have the same heavy duty construction as the larger units
- Very low maintenance
- Screens can be replaced easily for different types of product leaning
- Modules for air separation, metering feed, and additional screen area available



Other Features

Gentle vibratory feeder for 0% damage to crops

Aggressive design enables handling of rough materials

All standard bearings and replacement parts

Designed and built by seeds men

Manufactured in the U.S.A.

Large air settling chambers for even & accurate air separation

Low HP requirements, 1/2 HP on machine and 3 HP on fan

Large selection of screens available: from 27 sq. feet of screen

Screens available in all steel construction

**P.O. Box 3167, Great Falls, MT 59403 Ph. 406-727-6514 or 1-800-977-6514
www.benchindustries.com**

Flow Diagram

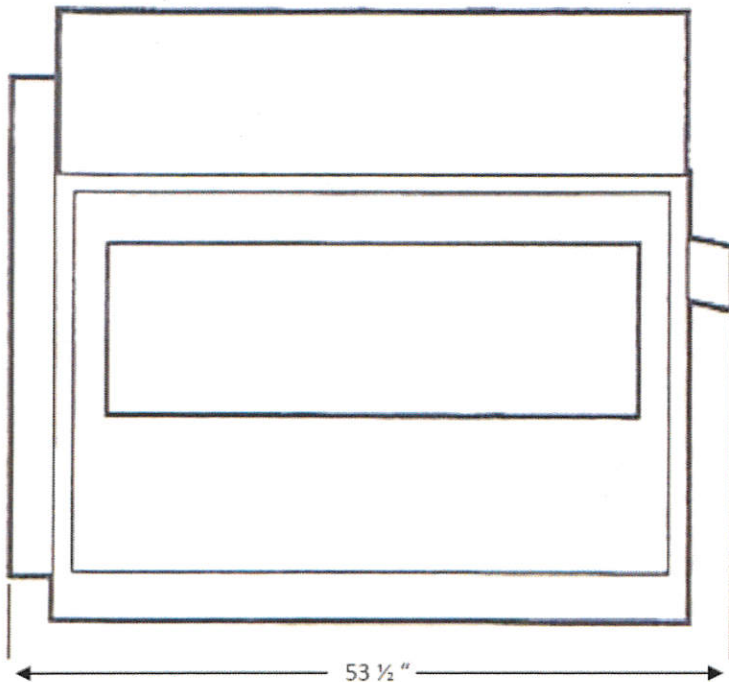
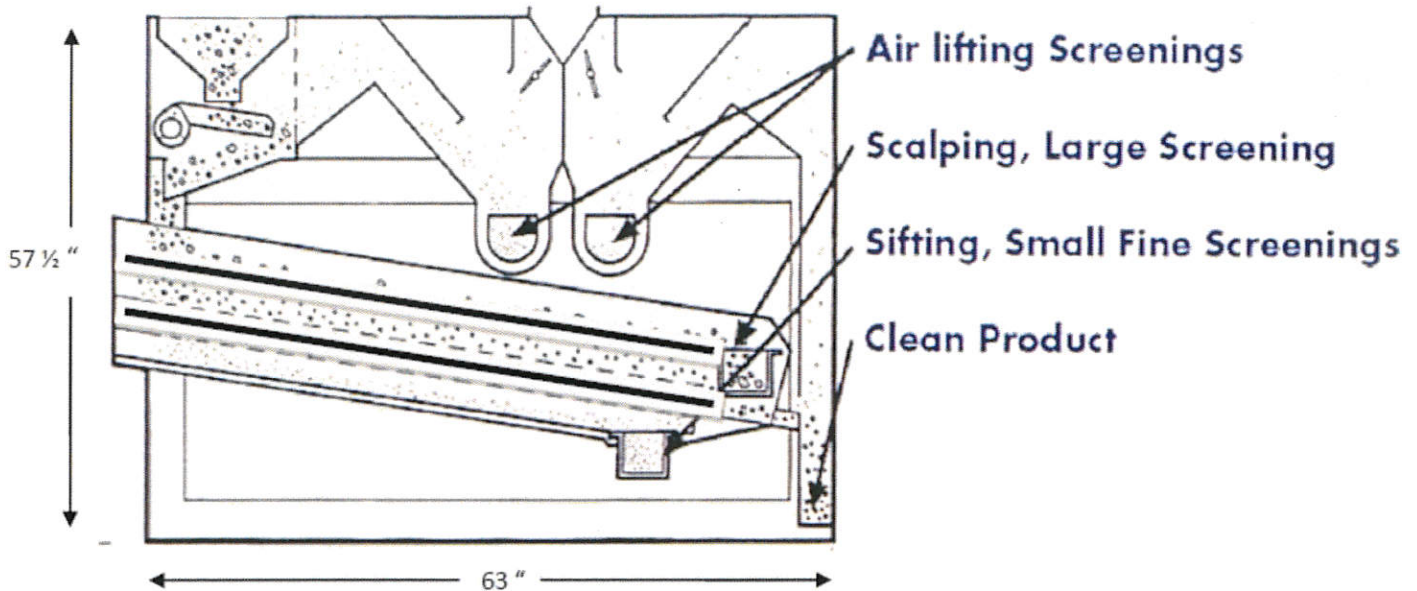

Specifications

Pre-Cleaning Capacity	500 Bu
Seed Cleaning Capacity	200 Bu
Screen Area	27 Sq Ft.

Power Requirements

Fan	3 HP
Shoe	1 HP
Air Volume	up to 5000 CFM
Shipping Weight	1780 lbs